

# ADAPTIV<sup>TM</sup> MOTORCYCLE ACCESSORY MOUNT

## RESERVOIR MOUNT INSTALLATION

ADAPTIV<sup>TM</sup>  
TECHNOLOGIES

### CONTENTS

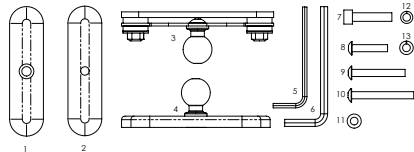

Item No.	Name	Quantity
1	Link Left	1
2	Left Right	1
3	Mounting Plate	1
4	Base Plate	1
5	2.5mm Hex Key	1
6	5/32" Hex Key	1
7	Positioning Screw	1
8	M4 x 20mm Screw	4
9	M4 x 30mm Screw	4
10	M4 x 35mm Screw	4
11	Spacer	4
12	Positioning Lock Washer	1
13	M4 Lock Washer	4

*This mount is designed for attachment to the brake reservoir on many motorcycles.*



**Warning: Installation of the mount should be performed by a qualified technician. Improper installation may interfere with the safety and proper operation of the product and/or vehicle.**

1. Place the motorcycle on a center stand.
2. Remove the factory installed screws that fasten the cover to the brake reservoir. These screws will not be reused.
3. If the brake reservoir has 4 screws, use the *2.5mm Hex Key* to fasten the *Base Plate* to the brake reservoir cover with the appropriate length *M4 Screws*, *M4 Lock Washers*, and *Spacers* as shown in Figure 1. If the brake reservoir has 2 screws, fasten the *Base Plate* to the brake reservoir cover with the appropriate length *M4 Screws*, *M4 Lock Washers*, and *Spacers* as shown in Figure 2.

Note: Do not remove or discard the bike's brake reservoir cover! The mount is designed to sit on top of the cover.

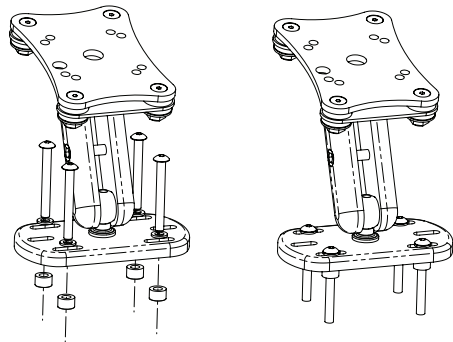

Figure 1

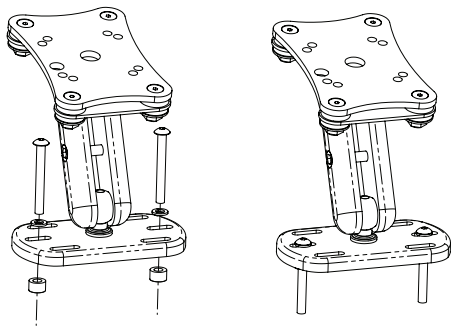

Figure 2

4. Using the  $5/32$ " Hex Key, loosen the *Positioning Screw* as shown in Figure 3.

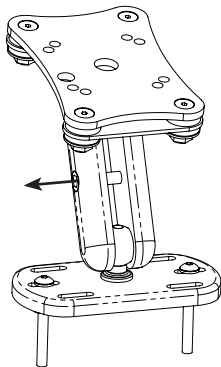
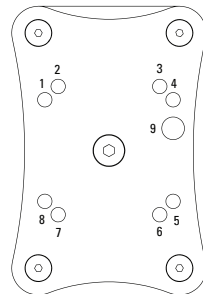

Figure 3

5. Fasten the accessory device or cradle to the top of the *Mounting Plate* utilizing appropriate hardware. The eight "AMPS" pattern holes (1-8) will accommodate #8 or M4 screws. The larger hole (9) will accommodate a  $1/4$ " or M6 screw. Alternatively, double sided adhesive tape or hook and loop fastener may be used.



Mounting Plate Holes

6. Adjust the mount to the desired position and tighten the *Positioning Screw* to lock the assembly in place.



**Warning:** Verify that the position of the mount and accessory will not interfere with proper operation of the vehicle.



**Warning:** Make sure all screws and nuts are securely tightened before each ride so that the assembly will not move during use.

#### Adaptiv Technologies

1639 11th Street  
Suite 156  
Santa Monica, CA 90404

[www.AdaptivTech.com](http://www.AdaptivTech.com)

866-ADAPTIV  
(866-232-7848)  
646-722-0253